

International
IR Rectifier

Integrated Power Hybrid IC for
Appliance Motor Drive Applications

IRAM136-1060B
iMOTION™ Series

10A, 600V
with Internal Shunt Resistor

Description

International Rectifier's IRAM136-1060B is a 10A, 600V Integrated Power Hybrid IC designed for advanced Appliance Motor Drives applications. Typical applications include energy efficient Washing Machine, Fans, Air Conditions and Refrigerator Compressor Drivers. This module offers an extremely compact, high performance AC motor-driver in an isolated package that simplifies design. Several built-in protection features such as over current, temperature monitoring, shoot through prevention and under voltage lockout makes this a very robust solution. The combination of highly efficient Trench IGBT technology and the industry benchmark 3-phase HVIC driver (3.3V/5V input compatible) and a fully isolated thermally enhanced package makes this a highly competitive solution. The compact Single in line (SIP05) package minimizes PCB space.

Features

- Internal Shunt Resistor and current feedback
- Integrated gate drivers and bootstrap diodes
- Temperature feedback
- Programmable over current protection pin
- High efficiency Trench IGBT technology
- Under-voltage lockout for all channels
- Matched propagation delay for all channels
- 3.3V/5V Schmitt-triggered input logic
- Cross-conduction prevention logic
- Motor Power range 0.25~0.75kW / 85~253 Vac
- Isolation 2000V_{RMS} min and CTI> 600



Absolute Maximum Ratings

| | | | |
|---------------------------|--|-------------|------------------|
| V_{CES} / V_{RRM} | IGBT/ FW Diode Blocking Voltage | 600 | V |
| V^+ | Positive Bus Input Voltage | 450 | |
| $I_o @ T_C=25^{\circ}C$ | RMS Phase Current (Note 1) | 10 | A |
| $I_o @ T_C=100^{\circ}C$ | RMS Phase Current (Note 1) | 5 | |
| I_{pk} | Maximum Peak Phase Current (Note 2) | 13 | |
| F_p | Maximum PWM Carrier Frequency | 20 | kHz |
| P_d | Maximum Power dissipation per IGBT @ $T_c = 25^{\circ}C$ | 25 | W |
| V_{ISO} | Isolation Voltage (1min) | 2000 | V _{RMS} |
| T_j (IGBT & Diode & IC) | Maximum Operating Junction Temperature | +150 | °C |
| T_c | Operating Case Temperature Range | -20 to +100 | |
| T_{STG} | Storage Temperature Range | -40 to +125 | |
| T | Mounting torque Range (M3 screw) | 0.8 to 1.0 | |
| | | | Nm |

Note 1: Sinusoidal Modulation at $V^+=400V$, $T_j=150^{\circ}C$, $F_{PWM}=16kHz$, Modulation Depth=0.8, PF=0.6, See Figure 3.

Note 2: $t_p < 100ms$, $T_C=25^{\circ}C$, $F_{PWM}=16kHz$.

IRAM136-1060B

Internal Electrical Schematic – IRAM136-1060B

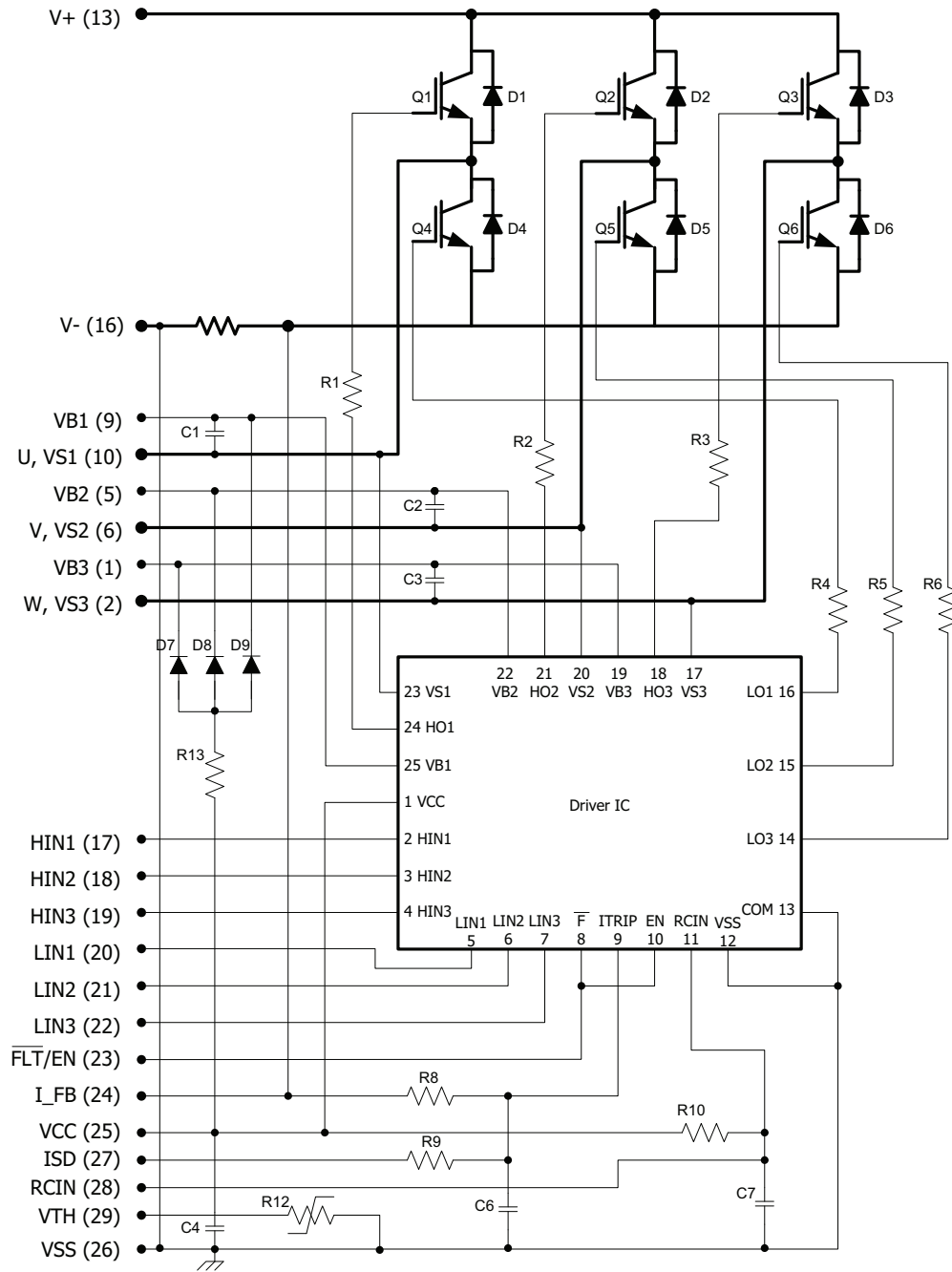

Absolute Maximum Ratings (Continued)

| Symbol | Parameter | Min | Max | Units | Conditions |
|----------------|--|-------------------|--|-------|---|
| $P_{BR\ Peak}$ | Bootstrap Resistor Peak Power (Single Pulse) | --- | 15.0 | W | $t_p=100\mu s, T_C=100^\circ C$ ESR / ERJ series |
| $V_{S1,2,3}$ | High side floating supply offset voltage | $V_{B1,2,3} - 25$ | $V_{B1,2,3} + 0.3$ | V | |
| $V_{B1,2,3}$ | High side floating supply voltage | -0.3 | 600 | V | |
| V_{CC} | Low Side and logic fixed supply voltage | -0.3 | 20 | V | |
| V_{IN} | Input voltage LIN, HIN, I_{TRIP} | -0.3 | Lower of ($V_{SS}+15V$) or $V_{CC}+0.3V$ | V | |

Inverter Section Electrical Characteristics @ $T_J=25^\circ C$

| Symbol | Parameter | Min | Typ | Max | Units | Conditions |
|---------------------------------|---|-----|------|---------|---------------|---|
| $V_{(BR)CES}$ | Collector-to-Emitter Breakdown Voltage | 600 | --- | --- | V | $V_{IN}=0V, I_C=250\mu A$ |
| $\Delta V_{(BR)CES} / \Delta T$ | Temperature Coeff. Of Breakdown Voltage | --- | 0.3 | --- | V/ $^\circ C$ | $V_{IN}=0V, I_C=250\mu A$ ($25^\circ C - 150^\circ C$) |
| $V_{CE(ON)}$ | Collector-to-Emitter Saturation Voltage | --- | 1.5 | 1.7 | V | $I_C=5A, T_J=25^\circ C$ |
| | | --- | 1.7 | --- | | $I_C=5A, T_J=150^\circ C$ |
| I_{CES} | Zero Gate Voltage Collector Current | --- | 5 | 80 | μA | $V_{IN}=0V, V^+=600V$ |
| | | --- | 80 | --- | | $V_{IN}=0V, V^+=600V, T_J=150^\circ C$ |
| V_{FM} | Diode Forward Voltage Drop | -- | 1.8 | 2.35 | V | $I_F=5A$ |
| | | --- | 1.45 | --- | | $I_F=5A, T_J=150^\circ C$ |
| V_{BDFM} | Bootstrap Diode Forward Voltage Drop | -- | 1.2 | -- | V | $I_F=1A$ |
| R_{BR} | Bootstrap Resistor Value | --- | 22 | --- | Ω | $T_J=25^\circ C$ |
| $\Delta R_{BR}/R_{BR}$ | Bootstrap Resistor Tolerance | --- | --- | ± 5 | % | $T_J=25^\circ C$ |
| I_{BUS_TRIP} | Current Protection Threshold (positive going) | --- | 20 | --- | A | ISD=Vss. See fig. 2 and fig. 11b |
| | | --- | 15 | --- | | ISD=Open. See fig. 2 and fig. 11b |

Inverter Section Switching Characteristics @ $T_j = 25^\circ\text{C}$

| Symbol | Parameter | Min | Typ | Max | Units | Conditions |
|-----------|-----------------------------------|-------------|-----|-----|---------------|--|
| E_{ON} | Turn-On Switching Loss | --- | 240 | 400 | μJ | $I_C=5\text{A}$, $V^+=400\text{V}$ $V_{CC}=15\text{V}$, $L=1.2\text{mH}$ Energy losses include "tail" and diode reverse recovery |
| E_{OFF} | Turn-Off Switching Loss | --- | 65 | 90 | | |
| E_{TOT} | Total Switching Loss | --- | 305 | 490 | | |
| E_{REC} | Diode Reverse Recovery energy | --- | 15 | 25 | | |
| t_{RR} | Diode Reverse Recovery time | --- | 115 | --- | ns | See CT1 |
| E_{ON} | Turn-on Switching Loss | --- | 330 | --- | μJ | $I_C=5\text{A}$, $V^+=400\text{V}$ $V_{CC}=15\text{V}$, $L=1.2\text{mH}$, $T_j=150^\circ\text{C}$ Energy losses include "tail" and diode reverse recovery |
| E_{OFF} | Turn-off Switching Loss | --- | 105 | --- | | |
| E_{TOT} | Total Switching Loss | --- | 435 | --- | | |
| E_{REC} | Diode Reverse Recovery energy | --- | 40 | --- | | |
| t_{RR} | Diode Reverse Recovery time | --- | 150 | --- | ns | See CT1 |
| Q_G | Turn-On IGBT Gate Charge | --- | 19 | 29 | nC | $I_C=8\text{A}$, $V^+=400\text{V}$, $V_{GE}=15\text{V}$ |
| RBSOA | Reverse Bias Safe Operating Area | FULL SQUARE | | | | $T_j=150^\circ\text{C}$, $I_C=5\text{A}$, $V_p=600\text{V}$ $V^+=450\text{V}$, $V_{CC}=+15\text{V}$ to 0V See CT3 |
| SCSOA | Short Circuit Safe Operating Area | 5 | --- | --- | μs | $T_j=25^\circ\text{C}$, $V_p=600\text{V}$, $V^+=360\text{V}$, $V_{CC}=+15\text{V}$ to 0V See CT2 |
| I_{CSC} | Short Circuit Collector Current | --- | 50 | --- | A | $T_j=25^\circ\text{C}$, $V^+=400\text{V}$, $V_{CC}=15\text{V}$ See CT2 |

Recommended Operating Conditions Driver Function

The Input/Output logic timing diagram is shown in Figure 1. For proper operation the device should be used within the recommended conditions. All voltages are absolute referenced to COM. The V_s offset is tested with all supplies biased at 15V differential (Note 3)

| Symbol | Definition | Min | Typ | Max | Units |
|--------------|--|----------|----------|------------|---------------|
| $V_{B1,2,3}$ | High side floating supply voltage | V_s+12 | V_s+15 | V_s+20 | V |
| $V_{S1,2,3}$ | High side floating supply offset voltage | Note 4 | --- | 450 | |
| V_{CC} | Low side and logic fixed supply voltage | 12 | 15 | 20 | V |
| V_{TRIP} | I_{TRIP} input voltage | V_{SS} | --- | $V_{SS}+5$ | |
| V_{IN} | Logic input voltage LIN, HIN | V_{SS} | --- | $V_{SS}+5$ | V |
| HIN | High side PWM pulse width | 1 | --- | --- | μs |
| Deadtime | External dead time between HIN and LIN | 1 | --- | --- | μs |

Note 3: For more details, see IR21364 data sheet

Note 4: Logic operational for V_s from COM-5V to COM+600V. Logic state held for V_s from COM-5V to COM- V_{BS} . (please refer to DT97-3 for more details)

Static Electrical Characteristics Driver Function @ T_j= 25°C

V_{BIAS} (V_{CC}, V_{BS1,2,3})=15V, unless otherwise specified. The V_{IN} and I_{IN} parameters are referenced to COM and are applicable to all six channels. (Note 3)

| Symbol | Definition | Min | Typ | Max | Units |
|---|---|------|------|------|-------|
| V _{IN,th+} | Positive going input threshold | 2.5 | --- | --- | V |
| V _{IN,th-} | Negative going input threshold | --- | --- | 0.8 | V |
| V _{CCUV+} , V _{BSUV+} | V _{CC} and V _{BS} supply undervoltage, Positive going threshold | 10.6 | 11.1 | 11.6 | V |
| V _{CCUV-} , V _{BSUV-} | V _{CC} and V _{BS} supply undervoltage, Negative going threshold | 10.4 | 10.9 | 11.4 | V |
| V _{CCUVH} , V _{BSUVH} | V _{CC} and V _{BS} supply undervoltage lock-out hysteresis | --- | 0.2 | --- | V |
| I _{QBS} | Quiescent V _{BS} supply current | --- | --- | 120 | μA |
| I _{QCC} | Quiescent V _{CC} supply current | --- | --- | 4 | mA |
| I _{LK} | Offset Supply Leakage Current | --- | --- | 50 | μA |
| I _{IN+} | Input bias current V _{IN} =3.3V | --- | 100 | 195 | μA |
| I _{IN-} | Input bias current V _{IN} =0V | -1 | -- | --- | μA |
| I _{TRIP+} | I _{TRIP} bias current V _{T/ITRIP} =3.3V | --- | 3.3 | 6 | μA |
| I _{TRIP-} | I _{TRIP} bias current V _{T/ITRIP} =0V | -1 | --- | --- | μA |
| V(I _{TRIP}) | I _{TRIP} threshold Voltage | 0.44 | 0.49 | 0.54 | V |
| V(I _{TriP} , HYS) | I _{TRIP} Input Hysteresis | --- | 0.07 | --- | V |

Dynamic Electrical Characteristics @ T_j= 25°C

Driver only timing unless otherwise specified.

| Symbol | Parameter | Min | Typ | Max | Units | Conditions |
|------------------------|---|-----|------|------|-------|---|
| T _{ON} | Input to Output propagation turn-on delay time (see fig.11) | --- | --- | 1.15 | μs | I _C =5A, V ⁺ =300V |
| T _{OFF} | Input to Output propagation turn-off delay time (see fig. 11) | --- | --- | 1.15 | μs | |
| T _{FLT} | Input Filter Time (HIN, LIN) | 100 | 200 | --- | ns | V _{IN} =0 or V _{IN} =5V |
| T _{BLT-ITRIP} | I _{TRIP} Blanking Time | 100 | 150 | --- | ns | V _{IN} =0 or V _{IN} =5V, V _{ITRIP} =5V |
| D _T | Dead Time | 220 | 290 | 360 | ns | V _{IN} =0 or V _{IN} =5V |
| M _T | Matching Propagation Delay Time (On & Off) all channels | --- | 40 | 75 | ns | External dead time > 400ns |
| T _{ITRIP} | I _{TRIP} to six switch turn-off propagation delay (see fig. 2) | --- | --- | 1.75 | μs | I _C =5A, V ⁺ =300V |
| T _{FLT-CLR} | FAULT clear time (see fig. 2) | --- | 32.0 | --- | ms | T _C = 25°C |

Thermal and Mechanical Characteristics

| Symbol | Parameter | Min | Typ | Max | Units | Conditions |
|---------------|--|-----|-----|-----|-------|---|
| $R_{th(J-C)}$ | Thermal resistance, per IGBT | --- | 4.6 | 5.0 | °C/W | Inverter Operating Condition Flat, greased surface. Heatsink compound thermal conductivity 1W/mK |
| $R_{th(J-C)}$ | Thermal resistance, per Diode | --- | 6.9 | 7.6 | | |
| $R_{th(C-S)}$ | Thermal resistance, C-S | --- | 0.1 | --- | | |
| C_D | Creepage Distance, from pins to backside of module | 3.2 | --- | --- | mm | See outline Drawings |
| CTI | Comparative Tracking Index | 600 | --- | --- | - | |

Internal NTC - Thermistor Characteristics

| Parameter | Definition | Min | Typ | Max | Units | Conditions |
|---------------------------|----------------------|------|------|------|------------|------------------------------------|
| R_{25} | Resistance | 97 | 100 | 103 | k Ω | $T_C = 25^\circ\text{C}$ |
| R_{125} | Resistance | 2.25 | 2.52 | 2.80 | k Ω | $T_C = 125^\circ\text{C}$ |
| B | B-constant (25-50°C) | 4165 | 4250 | 4335 | k | $R_2 = R_1 e^{[B(1/T_2 - 1/T_1)]}$ |
| Temperature Range | | -40 | --- | 125 | °C | |
| Typ. Dissipation constant | | --- | 1 | --- | mW/°C | $T_C = 25^\circ\text{C}$ |

Internal Current Sensing Resistor - Shunt Characteristics

| Symbol | Parameter | Min | Typ | Max | Units | Conditions |
|-------------|-------------------------|------|------|------|------------|---|
| R_{Shunt} | Resistance | 32.9 | 33.3 | 33.7 | m Ω | $T_C = 25^\circ\text{C}$ |
| T_{Coeff} | Temperature Coefficient | 0 | --- | 200 | ppm/°C | |
| P_{Shunt} | Power Dissipation | --- | --- | 2.2 | W | $-40^\circ\text{C} < T_C < 100^\circ\text{C}$ |
| T_{Range} | Temperature Range | -40 | --- | 125 | °C | |

Input-Output Logic Level Table

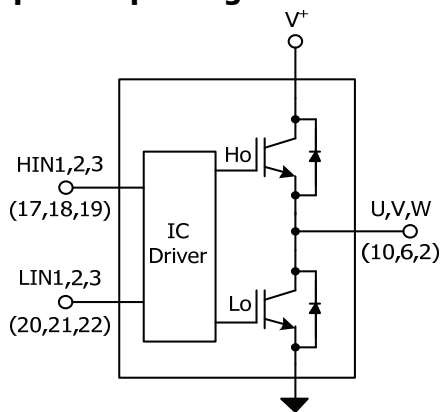

| $\overline{\text{FLT/EN}}$ | I_{TRIP} | HIN1,2,3 | LIN1,2,3 | U,V,W |
|----------------------------|------------|----------|----------|-------|
| 1 | 0 | 1 | 0 | V+ |
| 1 | 0 | 0 | 1 | 0 |
| 1 | 0 | 0 | 0 | Off |
| 1 | 0 | 1 | 1 | Off |
| 1 | 1 | X | X | Off |
| 0 | X | X | X | Off |

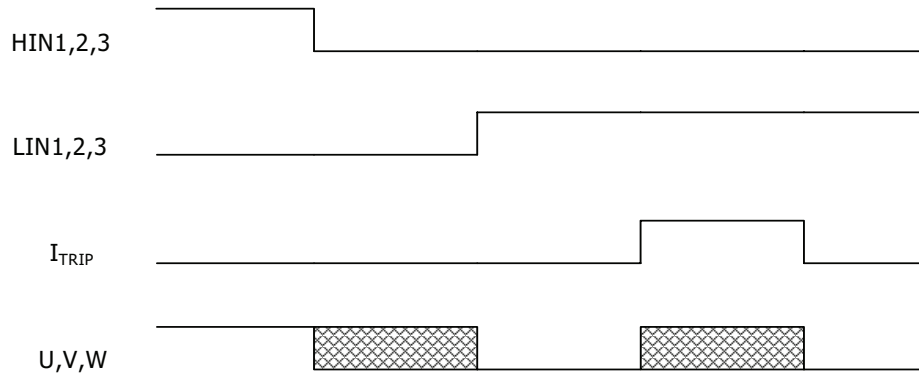

Figure 1. Input/Output Timing Diagram

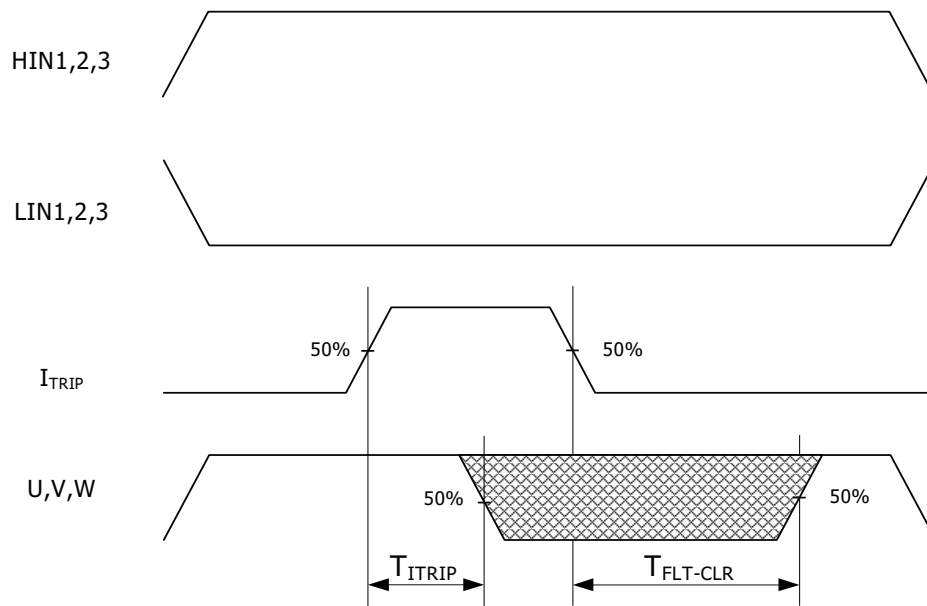

Figure 2. I_{TRIP} Timing Waveform

Note 5: The shaded area indicates that both high-side and low-side switches are off and therefore the half-bridge output voltage would be determined by the direction of current flow in the load.

Module Pin-Out Description

| Pin | Name | Description |
|-----|-----------------|---|
| 1 | VB3 | High Side Floating Supply Voltage 3 |
| 2 | W,VS3 | Output 3 - High Side Floating Supply Offset Voltage |
| 3 | na | none |
| 4 | na | none |
| 5 | VB2 | High Side Floating Supply voltage 2 |
| 6 | V,VS2 | Output 2 - High Side Floating Supply Offset Voltage |
| 7 | na | none |
| 8 | na | none |
| 9 | VB1 | High Side Floating Supply voltage 1 |
| 10 | U,VS1 | Output 1 - High Side Floating Supply Offset Voltage |
| 11 | na | none |
| 12 | na | none |
| 13 | V ⁺ | Positive Bus Input Voltage |
| 14 | na | none |
| 15 | na | none |
| 16 | V ⁻ | Negative Bus Input Voltage |
| 17 | HIN1 | Logic Input High Side Gate Driver - Phase 1 |
| 18 | HIN2 | Logic Input High Side Gate Driver - Phase 2 |
| 19 | HIN3 | Logic Input High Side Gate Driver - Phase 3 |
| 20 | LIN1 | Logic Input Low Side Gate Driver - Phase 1 |
| 21 | LIN2 | Logic Input Low Side Gate Driver - Phase 2 |
| 22 | LIN3 | Logic Input Low Side Gate Driver - Phase 3 |
| 23 | FLT/EN | Fault Output and Enable Pins |
| 24 | I _{FB} | Current Feedback Output Pin |
| 25 | V _{CC} | +15V Main Supply |
| 26 | V _{SS} | Negative Main Supply |
| 27 | ISD | Current Protection Level Programming Pin |
| 28 | RCIN | RCIN Reset Programming Pin |
| 29 | V _{TH} | Temperature Feedback |

Typical Application Connection IRAM136-1060B

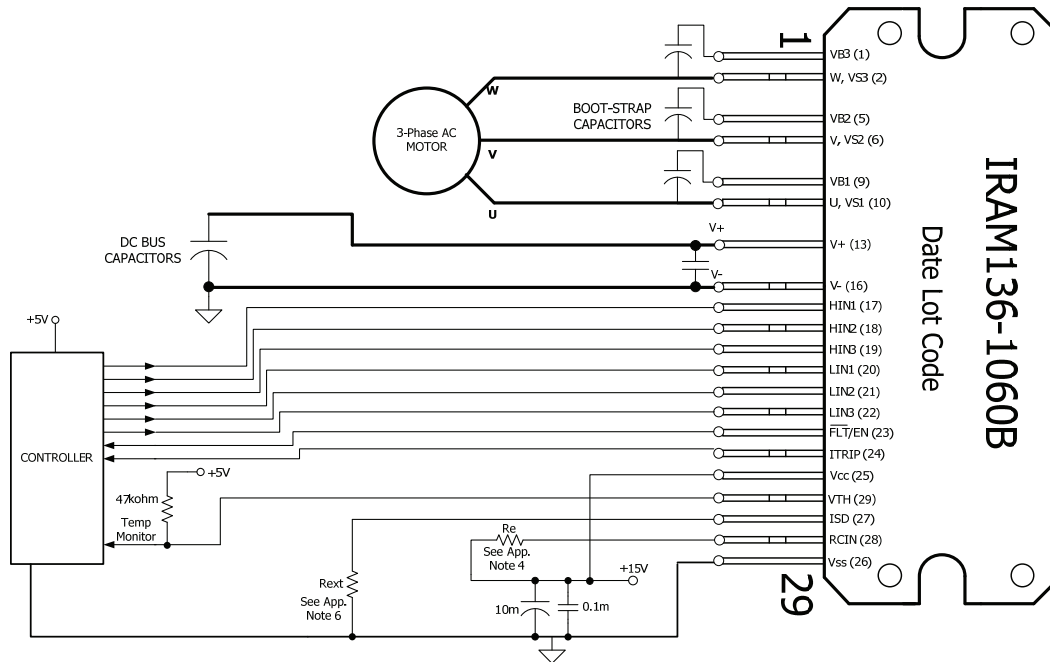

Application Notes

1. Electrolytic bus capacitors should be mounted as close to the module bus terminals as possible to reduce ringing and EMI problems. Mounting an additional high frequency ceramic capacitor close to the module pins is highly recommended.
2. In order to provide good decoupling between VCC-VSS and VB1,2,3-VS1,2,3 terminals, the capacitors shown connected between these terminals should be located very close to the module pins. Additional high frequency capacitors, typically 0.1 μ F, are strongly recommended.
3. Value of the boot-strap capacitors depends upon the switching frequency and modulation techniques. Their selection should be made based on IR design tip DN 98-2a, application note AN-1044 or Figure 9. Bootstrap capacitor value must be selected to limit the power dissipation of the internal resistor in series with the VCC. (See maximum ratings Table on page 3).
4. **WARNING!** Please note that after approx. 32ms the FAULT is automatically reset. (See Dynamic Characteristics Table on page 5). The default Fault clear time is when RCIN pin is open. Refer to Figure 11a for Re selection and desired RCIN setting.
5. PWM generator must be disabled within automatic reset time ($T_{FLT-CLR}$) to guarantee shutdown of the system, overcurrent condition must be cleared before resuming operation.
6. ISD can be programmed by using external resistor (Rext) connected to Vss. The default current level is when ISD pin is open (see Inverter Characteristics Table on page 3). Maximum current level can be achieved by connecting ISD to Vss. See Figure 11b for desired current level and resistor selection.
7. Fault/En pin (23) must be pulled-up to +5V.

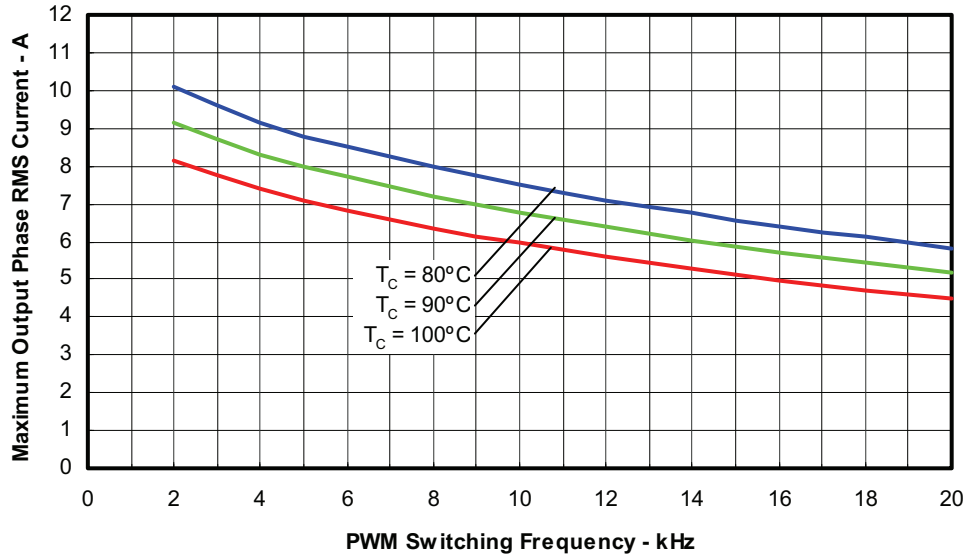

Figure 3. Maximum Sinusoidal Phase Current vs. PWM Switching Frequency Sinusoidal Modulation, $V^+ = 400\text{V}$, $T_j = 150^\circ\text{C}$, $MI = 0.8$, $PF = 0.6$, $f_{\text{mod}} = 100\text{Hz}$

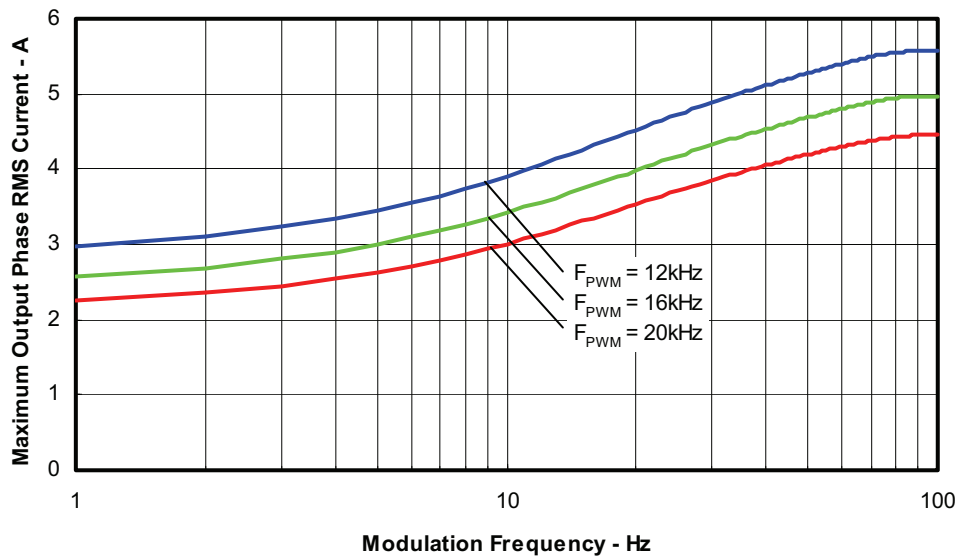

Figure 4. Maximum Sinusoidal Phase Current vs. Modulation Frequency Sinusoidal Modulation, $V^+ = 400\text{V}$, $T_j = 150^\circ\text{C}$, $T_c = 100^\circ\text{C}$, $MI = 0.8$, $PF = 0.6$

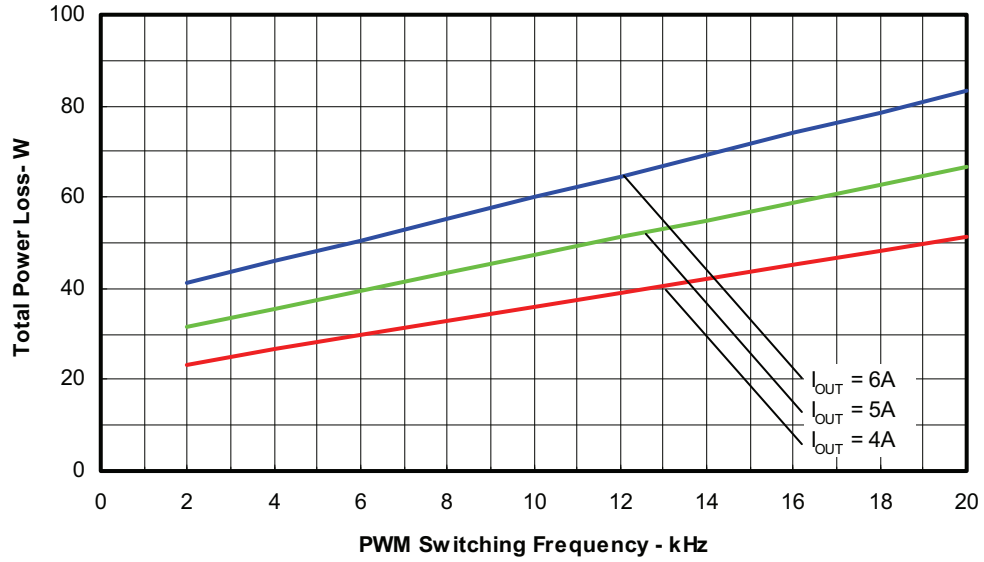

Figure 5. Total Power Losses vs. PWM Switching Frequency
Sinusoidal Modulation, $V^+ = 400V$, $T_J = 150^\circ C$, $MI = 0.8$, $PF = 0.6$, $f_{mod} = 100Hz$

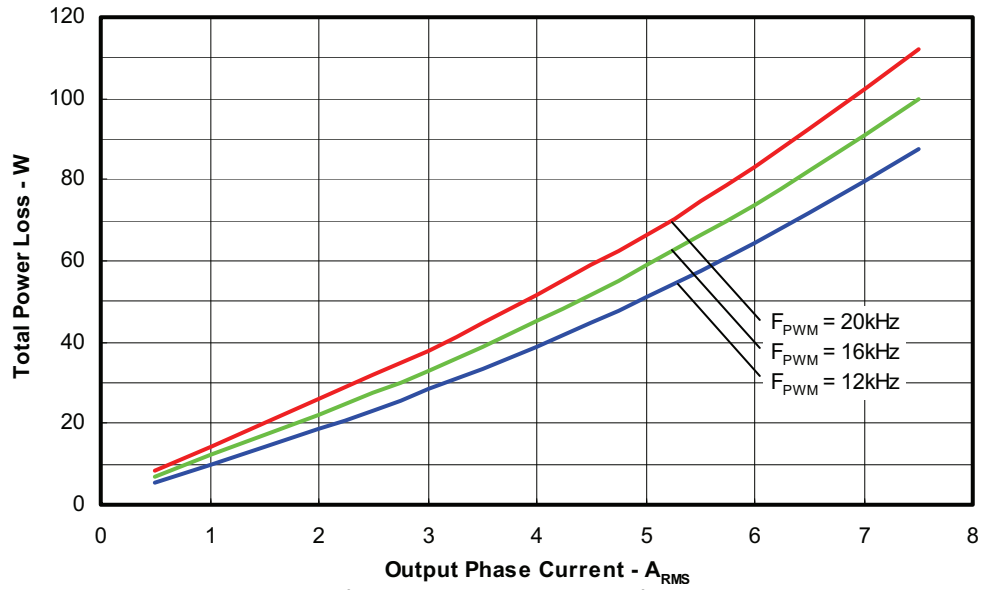

Figure 6. Total Power Losses vs. Output Phase Current
Sinusoidal Modulation, $V^+ = 400V$, $T_J = 150^\circ C$, $MI = 0.8$, $PF = 0.6$, $f_{mod} = 100Hz$

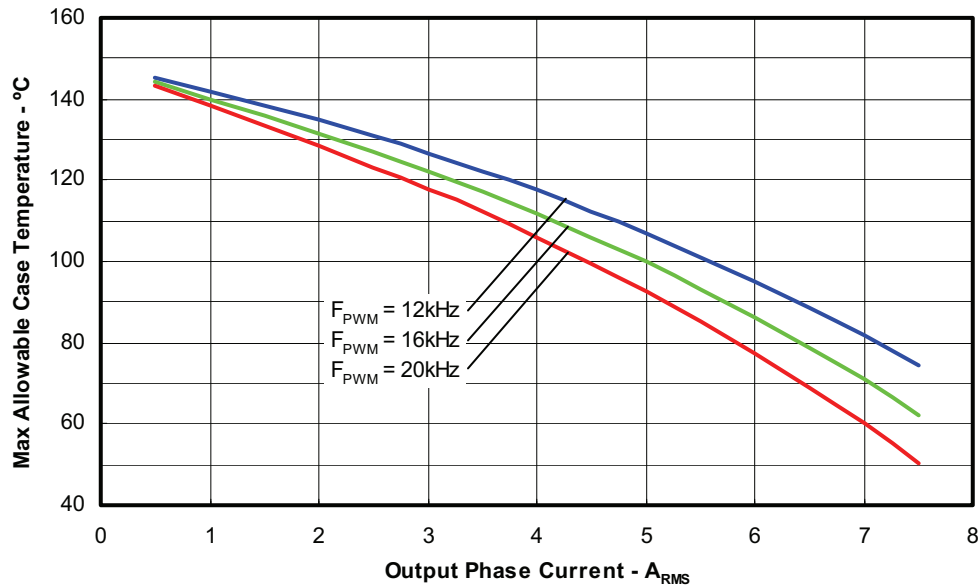

Figure 7. Maximum Allowable Case Temperature vs. Output RMS Current per Phase Sinusoidal Modulation, $V^+ = 400V$, $T_J = 150^\circ C$, $MI = 0.8$, $PF = 0.6$, $f_{mod} = 50Hz$

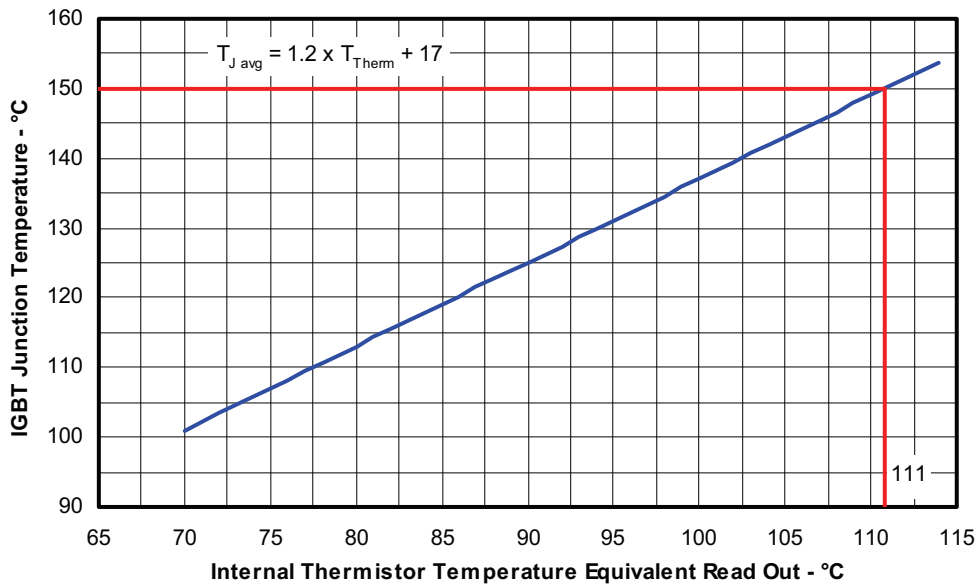

Figure 8. Estimated Maximum IGBT Junction Temperature vs. Thermistor Temperature Sinusoidal Modulation, $V^+ = 400V$, $I_{phase} = 5A_{rms}$, $f_{sw} = 16kHz$, $f_{mod} = 50Hz$, $MI = 0.8$, $PF = 0.6$

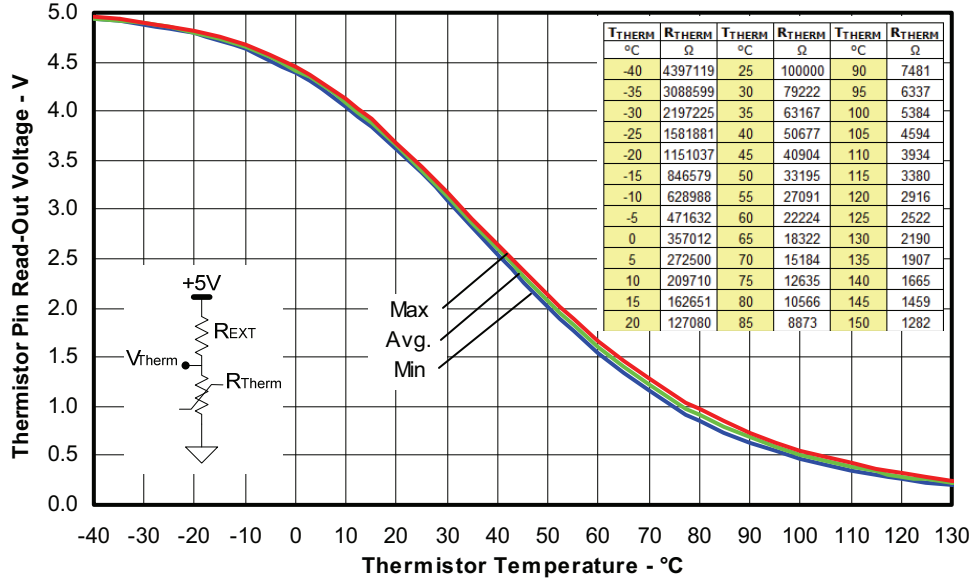

Figure 9. Thermistor Readout vs. Temperature (47kohm pull-up resistor, 5V) and Normal Thermistor Resistance values vs. Temperature Table.

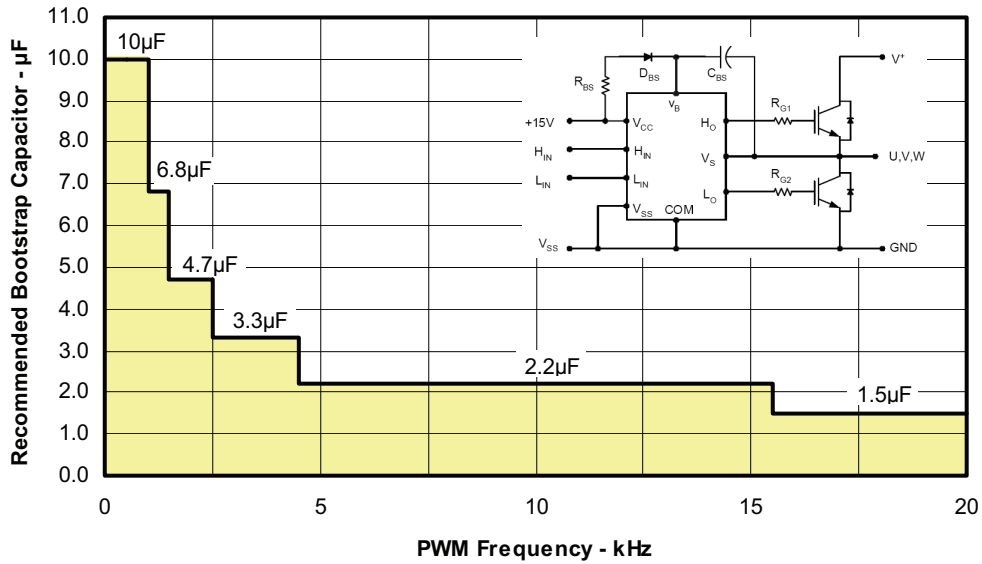

Figure 10. Recommended Bootstrap Capacitor Value vs. Switching Frequency

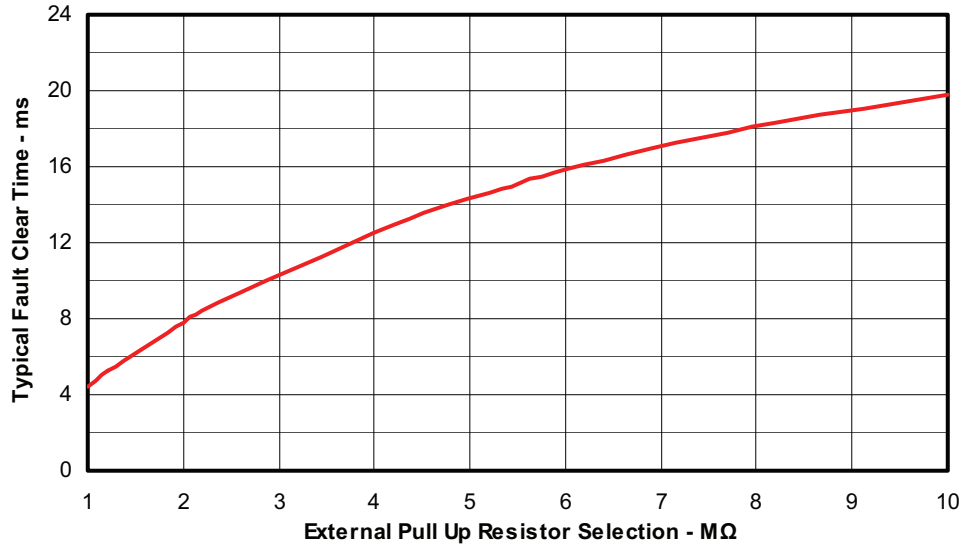

Figure 11a. External Pull Up resistor selection for Fault clear time
(Recommended minimum Pull up Resistor is 1MΩ)

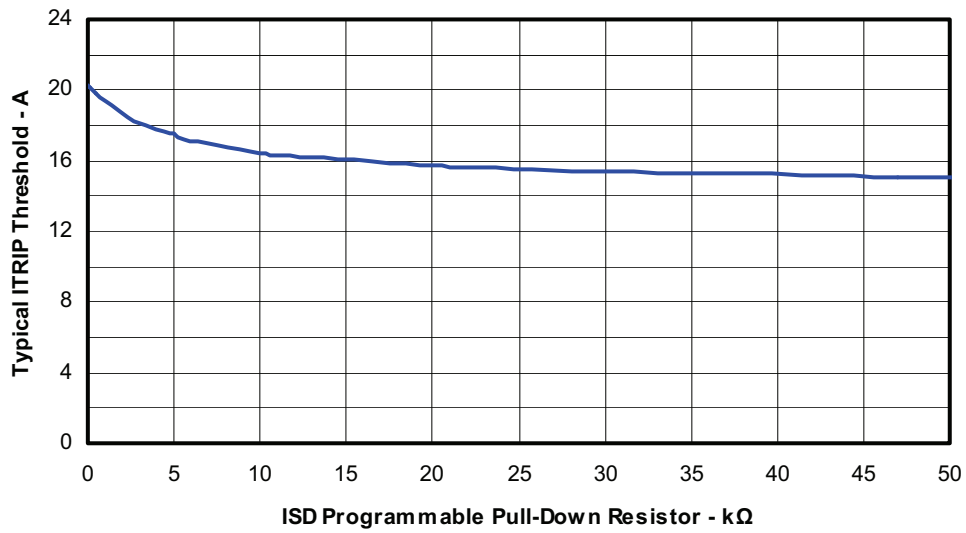

Figure 11b. Itrip Level External Pull down Resistor Selection

Figure 12. Switching Parameter Definitions

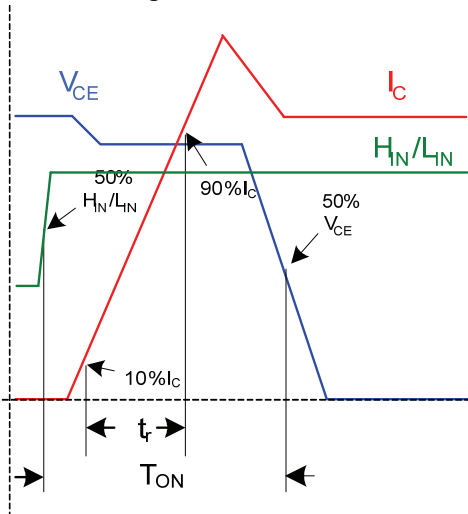

Figure 11a. Input to Output propagation turn-on delay time.

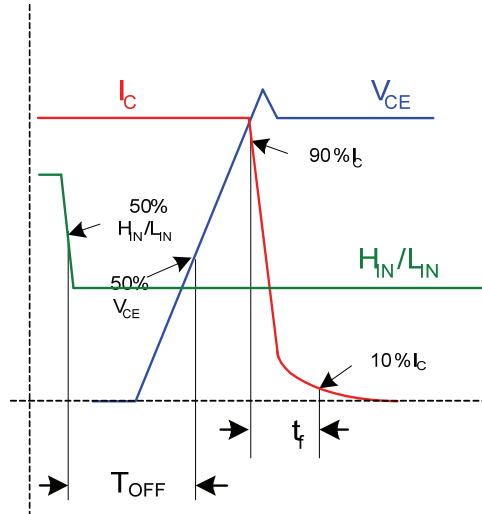

Figure 11b. Input to Output propagation turn-off delay time.

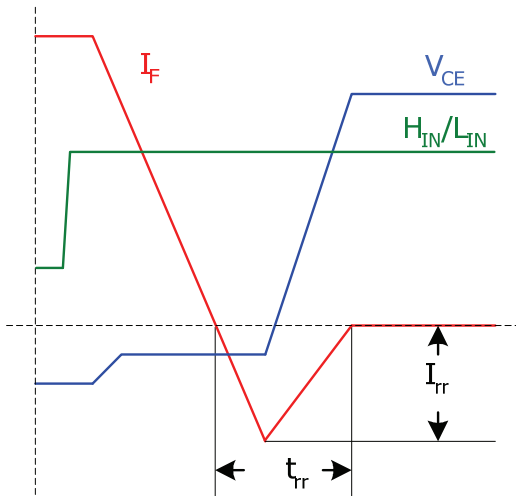

Figure 11c. Diode Reverse Recovery.

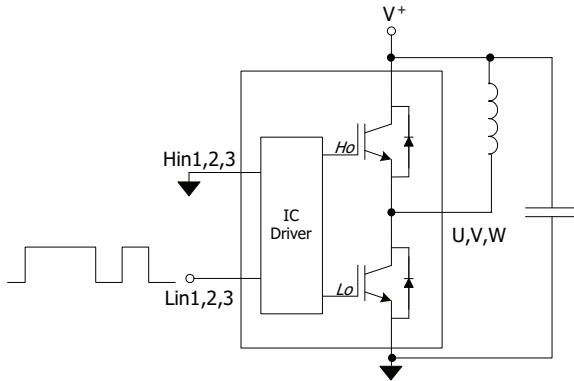

Figure CT1. Switching Loss Circuit

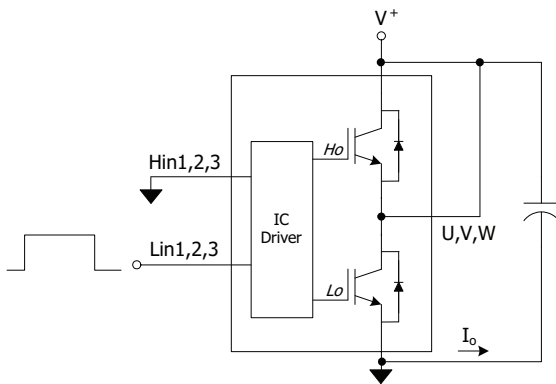
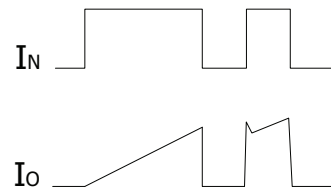

Figure CT2. S.C.SOA Circuit

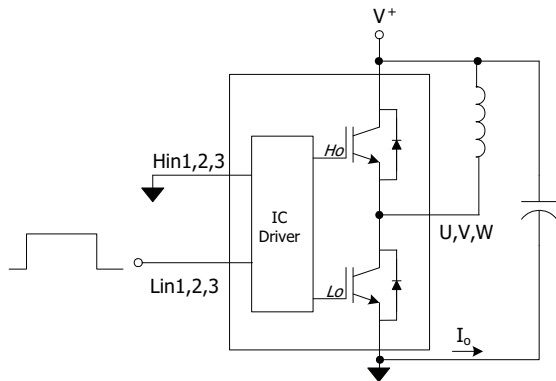
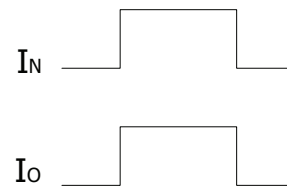
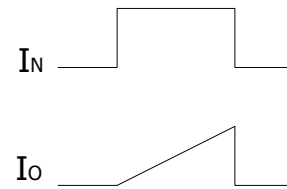
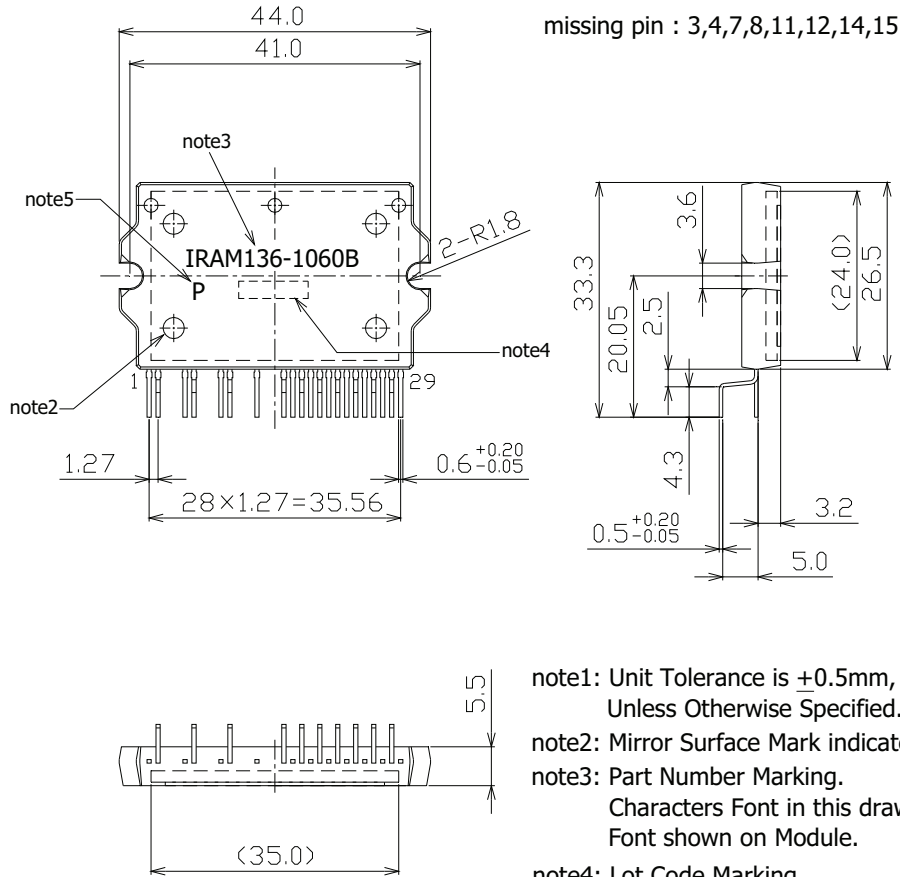

Figure CT3. R.B.SOA Circuit



Package Outline IRAM136-1060B



- note1: Unit Tolerance is ± 0.5 mm,
Unless Otherwise Specified.
- note2: Mirror Surface Mark indicates Pin1 Identification.
- note3: Part Number Marking.
Characters Font in this drawing differs from
Font shown on Module.
- note4: Lot Code Marking.
Characters Font in this drawing differs from
Font shown on Module.
- note5: "P" Character denotes Lead Free.
Characters Font in this drawing differs from
Font shown on Module.

Dimensions in mm
 For mounting instruction see AN-1049

IRAM136-1060B

Package Outline IRAM136-1060B2

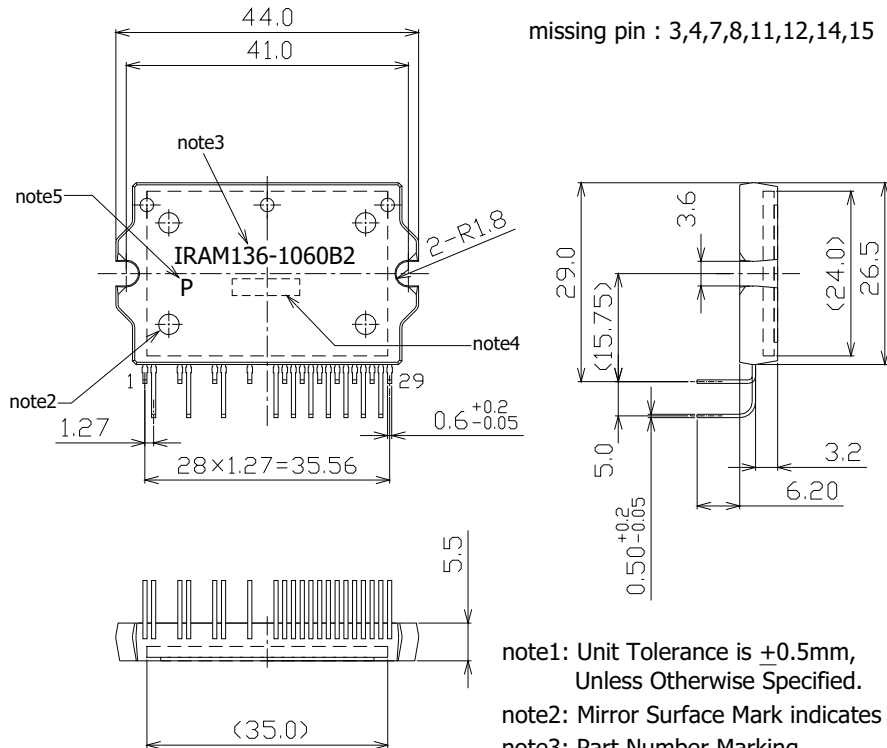

- note1: Unit Tolerance is ± 0.5 mm,
Unless Otherwise Specified.
- note2: Mirror Surface Mark indicates Pin1 Identification.
- note3: Part Number Marking.
Characters Font in this drawing differs from
Font shown on Module.
- note4: Lot Code Marking.
Characters Font in this drawing differs from
Font shown on Module.
- note5: "P" Character denotes Lead Free.
Characters Font in this drawing differs from
Font shown on Module.

Dimensions in mm
For mounting instruction see AN-1049